

DEPARTMENT OF THE ARMY TECHNICAL MANUAL

OPERATOR'S, ORGANIZATIONAL, DIRECT SUPPORT,
AND GENERAL SUPPORT MAINTENANCE MANUAL
TEST FACILITY SETS

TS-2644 / ASN AND TS-2645 / ASN

Headquarters, Department of the Army, Washington, D.C.
14 December 1973

		Paragraph	Page
CHAPTER	1. INTRODUCTION		
SECTION	I. General		
	Scope	1-1	3
	Forms records	1-2	3
	Equipment serviceability criteria (ESC)	1-3	3
	Destruction of Army materiel to prevent enemy use	1-4	3
	Administrative storage.	1-5	3
	Calibration	1-6	3
	Reporting of Equipment Publication Improvements.	1-7	3
	II. Description and data		
	Purpose and use.	1-8	3
	Description.	1-9	3
	Differences between models	1-10	4
	Tabulated data	1-11	4
	Items comprising an operable equipment.	1-12	4
CHAPTER	2. OPERATING INSTRUCTIONS		
Section	I. Service upon receipt of equipment		
	Checking unpacked equipment.	2-1	6
	Damage from improper settings.	2-2	6
	Operators controls.	2-3	6
	II. Operation under unusual conditions		
	Preliminary starting procedure.	2-4	7
	Initial adjustments	2-5	7
	Operating procedure	2-6	7
	Preparation for movement.	2-7	8
CHAPTER	3. FUNCTIONING OF EQUIPMENT		
	Functioning in of TS-2644 / ASN.	3-1	9
	Functioning TS-2645 / ASN.	3-2	10
CHAPTER	4. DIRECT SUPPORT AND GENERAL SUPPORT MAINTENANCE INSTRUCTIONS		
Section	I. General		
	Direct support maintenance.	4-1	11
	Voltage and resistance measurements	4-2	11
	Bench testing.	4-3	11
	Tools and test equipment required.	4-4	11
	II. Troubleshooting and repair		
	Troubleshooting procedure	4-5	11
	General support maintenance	4-6	11
	III. General support testing procedures		
	General	4-7	11

	Paragraph	Page
Physical tests and inspection	4-8	11
Insulation resistance test	4-9	11
Continuity test	4-10	13
APPENDIX A. REFERENCES		A-1
Section B. MAINTENANCE ALLOCATION		
I. Introduction		B-1
II. Maintenance allocation chart		B-3

CHAPTER 1

INTRODUCTION

Section I . GENERAL

1-1. Scope

This technical manual contains operator, organizational, direct support, and general support maintenance instructions for Test Facility Set TS-2644 / ASN and Test Facility Set TS-2645 / ASN.

1-2. Forms and Records

a. Reports of Maintenance and Unsatisfactory Equipment. Use equipment forms and records in accordance with instructions given in TM 38-750.

b. Report of Packaging and Handling Deficiencies. Fill out and forward DD Form 6 (Report of Packaging and Handling Deficiencies) as prescribed in AR 700-58 (Army) / NAVSUP Pub 378 (Navy/AFR 71-4 (Air Force)/ and MCO P4030.29 (Marine Corps).

c. Discrepancy in Shipment Report (DISREP) (SF 361). Fill out and forward Discrepancy in Shipment Report (DISREP) (SF 361) as prescribed in AR 55-38 (Army) / NAVSUP Pub 459 (Navy) / AFM 75-34 (Air Force)/ and MCO P4610.19 (Marine Corps).

1-3. Equipment Serviceability Criteria (ESC).

There are no EXC technical manuals for the equipments covered in this technical manual.

1-4. Destruction of Army Materiel to Prevent Enemy Use.

Demolition of the equipment will be accomplished only upon the order of the Commander. Refer to TM 750-244-2 for procedures to prevent enemy from using or salvaging this equipment.

1-5. Administrative Storage

For procedures, forms, records, and inspections required during administrative storage of this equipment, refer to TM 740-90-1.

1-6. Calibration

There are no calibration requirements for the equipment covered in this manual per TM 750-236.19 March 1973.

1-7. Reporting of Equipment Publication Improvements

The reporting of errors, omissions, and recommendations for improving this publication by the individual user is encouraged. Reports should be submitted on DA Form 2028 (Recommended Changes to Publications) and forwarded direct to Commander, US Army Electronics Command, ATTN: AMSEL-MA-AN, Fort Monmouth, NJ 07703.

Section II. DESCRIPTION AND DATA

1-8. Purpose and Use

a. The TS-2644 / ASN provides the necessary interconnections, controls, and test points to permit testing of Gyromagnetic Compass Set AN / ASN-43 with Radio-Magnetic Compass Indicator ID-998(*) / ASN as an operating system.

b. The TS-2645 / ASN provides the necessary interconnections, controls, cabling, and test points to permit testing of Gyromagnetic Compass Set AN / ASN-43 with Heading-Radio Bearing Indicator ID-1351 / A as an operating system.

c. The TS-2644 / ASN and TS-2645 / ASN incorporate the following methods of providing magnetic heading to the system under test:

(1) Self-contained magnetic heading simulator.

(2) Access cable and connector to mate with Induction Compass Transmitter T-611 / ASN.

(3) Access cable and connector to mate with external magnetic heading simulator.

1-9. Description (fig. 1-1)

The cover and case are constructed of deep-drawn aluminum alloy. The cover is hinged at the rear of the case with a separable-type hinge. Two latch-type fasteners cinch the cover against an extruded neoprene gasket that is secured on the mating surface of the case. A swivel-type carrying handle is attached to the top of the cover. The case and cover are finished with gray enamel.

a. Case and Cover Assembly. The case houses all controls, connectors, cabling, and electrical parts that comprise the test set. All test set controls are located on the panel which is recessed in the case. The connectors of cables W2, W3, and W4 are stowed in and secured by angle brackets mounted on the panel and in the cover. A schematic diagram of the test set is enclosed in laminated clear plastic and secured to the inside top surface of the cover with a bonding adhesive.

b. *Cabling.* Cables W1 through W4 are parts of a branched wiring harness. Cable W5 is a separate cable used for interconnection between the test set and Induction Compass Transmitter T-611 / ASN. Cable W5 is stowed beneath the panel when the T-611 / ASN is not used in the test setup. Cable W1 is a 5-foot, 115-volt, 400-Hz input power cable with leads to be dressed and tinned for connections as required. Cables W2, W3, and W4 are approximately 4½-foot lengths of cable, including

connectors. Cable W4 is approximately 1 foot in length including connector. All test set cabling is sleeved in heat-shrink tubing and identified as to cable designation and mating connector or destination.

c. *Panel.* The panel provides the mounting surface for all test set controls, test jacks, power-on lamp, and fuse. The left side of the panel has a cutout to allow exit of cables W1 through W4.

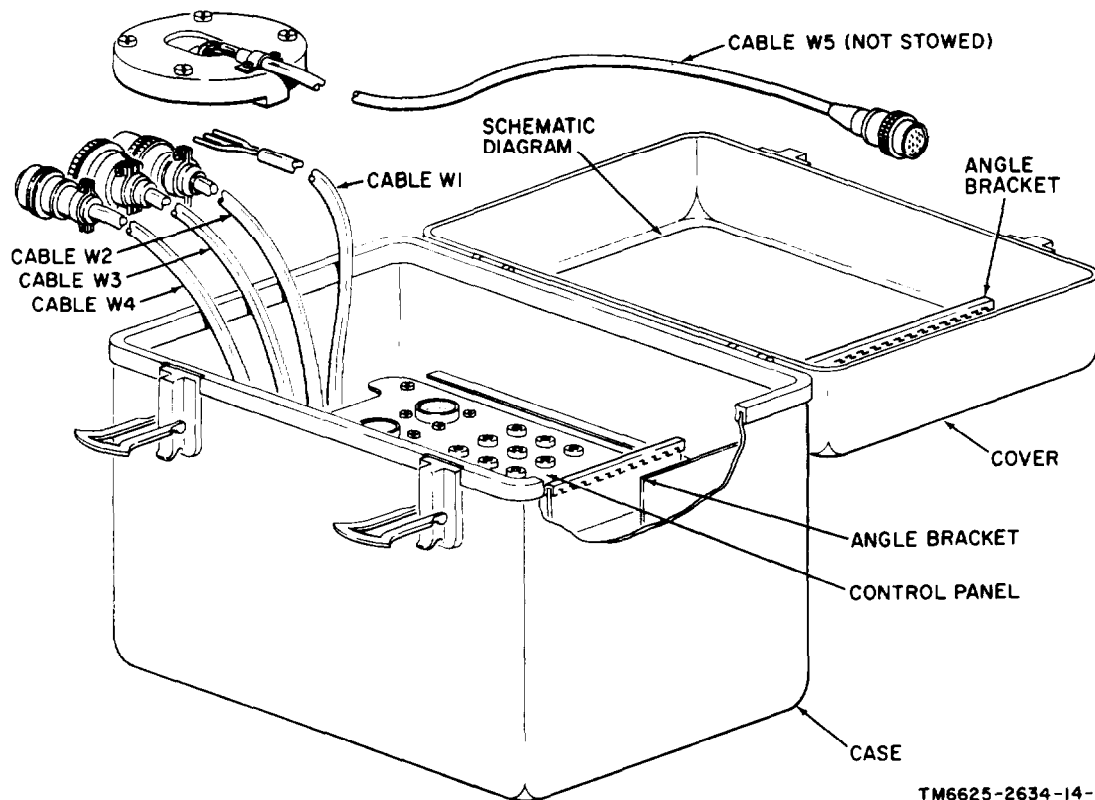

Figure 1-1. Typical test facility set.

1-10. Differences Between Models

The TS-2644 / ASN has an additional connector that mates with Amplifier AM-3209 / ASN. This connection is necessary to supply excitation to Radio-Magnetic Compass Indicator ID-998(*) / ASN when testing Gyromagnetic Compass Set AN/ ASN-43. The TS-2645 / ASN does not provide any interconnections to Heading-Radio Bearing Indicator ID-1351 / A other than connector 11P1.

NOTE

The symbol (*) indicates all models of the equipment.

1-11. Tabulated Data

Table 1-1 lists physical and performance data for the test sets.

1-12. Items Comprising an Operable Equipment

The following items comprise the operable Test Facility Sets TS-2644/ ASN and TS-2645 / ASN :

a. Cable W1 is a 5-foot, 115-volt, 400-Hz input power cable.

b. Cables W2, W3, and W5 are approximately 4½ feet long including connectors.

c. Cable W4 is approximately 1 foot long including connector.

Table 1-1. Test Set Physical and Performance Data

Physical data	
Height	6 7 / 8 in. (17 cm)
Width	11 in. (28 cm)
Depth	7 in. (18 cm)
Weight (maximum)	9 lb (3 kg)
Power	
Input power	115 ± 2Vac, 400 ± 5Hz
Accuracy	
Heading selector settings	± 0.5 deg

CHAPTER 2

OPERATING INSTRUCTIONS

Section I. SERVICE UPON RECEIPT OF EQUIPMENT

2-1. Checking Unpacked Equipment

a. Inspect the equipment for damage incurred during shipment. If the equipment has been damaged, report the damage on DD Form 6.

b. Check the equipment against the component listing and the packing slip to see if the shipment is complete. Report all discrepancies in accordance with the instructions of TM 38-750. The equipment may be placed in service if a minor assembly or part that does not affect proper functioning is missing.

c. Check to see whether the equipment has been modified. (Equipment that has been modified will have the M W O number on the front panel, near the nomenclature plate.) Also, check to see whether all

current applicable MWO's have been applied. (Current MWO's applicable to the equipment are listed in DA Pam 310-7.)

2-2. Damage from Improper Settings

When the test set is in proper working condition, no control settings or combination of settings will result in equipment damage or create a hazard to personnel.

2-3. Operator's Controls

Figure 2-1 illustrates the control panel for TS-2644 / ASN; figure 2-2 illustrates the control panel for TS-2645 / ASN. Table 2-1 provides functional information for the operator's controls on the test set control panel.

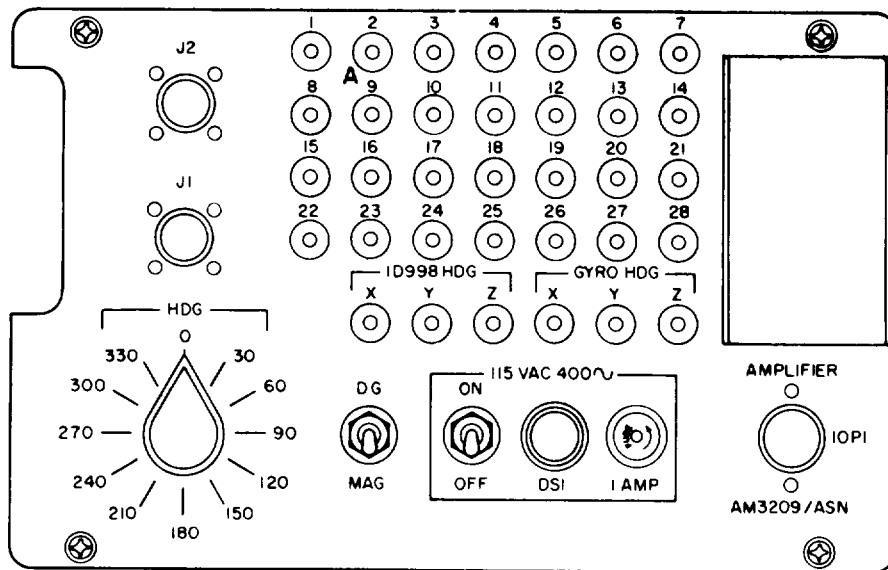

TM6625-2634-14-2

Figure 2-1. TS-2644 / ASN control panel.

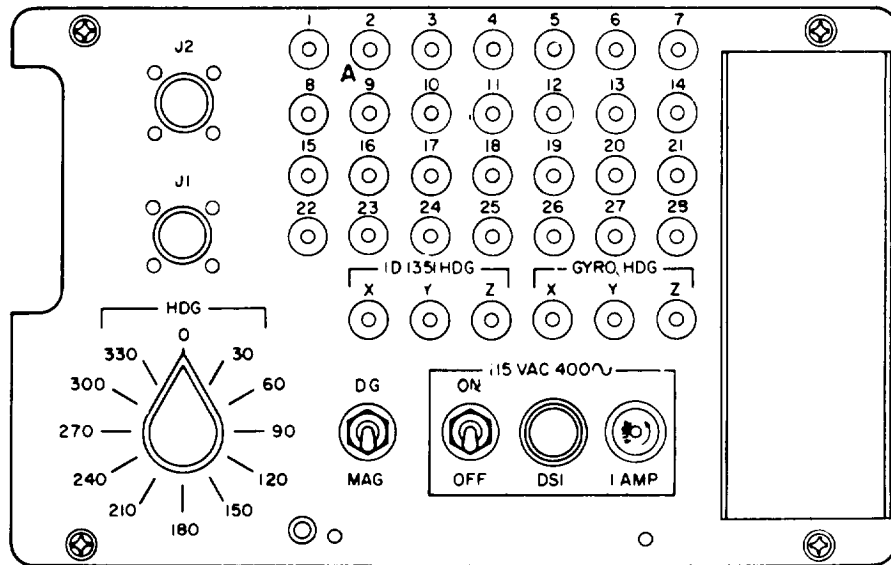

TM6625-2634-14-3

Figure 2-2. TS-2645 / ASN control panel.

Section II. OPERATION UNDER UNUSUAL CONDITIONS

2-4. Preliminary Starting Procedure

The appropriate neutral positions for the test set controls are as follows:

a. Power ON-OFF toggle switch should be set to OFF.

b. MAG-DG toggle switch should be set to MAG.

c. HDG rotary switch should be set to 0.

Table 2-1. Operator's Control Functions

Control panel switch	Function
115 VAC 400V ON-OFF switch S1 DC-MAC switch S2	Toggle switch (DPDT); connects input power to test set circuitry. Toggle switch (SPDT); permits Directional Gyro CN-988(*) / ASN to be operated in the earth-rate-corrected, free-gyro (DG) mode, or in the magnetically slaved (MAG) mode.
HDG switch S3	Controls test set magnetic heading simulator three-wire output. Selects simulated magnetic heading outputs from 0 degrees through 330 degrees in 30-degree increments.

2-5. Initial Adjustments

No initial adjustments are required on the test set.

2-6. Operating Procedure

The operating procedure for the test set when checking Gyromagnetic Compass Set AN / ASN-43 in a system is as follows:

a. Connect test set cable W1 to 115Vac, 400Hz power source.

b. Set ON-OFF switch to ON and observe that lamp DS1 lights.

c. Set ON-OFF switch to OFF, then attach test set cables to AN / ASN-43 components and indicator (ID-998(*)/ ASN or ID-1351 / A).

- d.* Set ON-OFF switch to ON.
- e.* Set MAG-DG switch to DG and rotate Directional Gyro CN-988(*) / ASN until indicator displays 180 degrees.
- f.* Set MAG-DG switch to MAG and observe indicator for a heading that agrees with HDG switch position.
- g.* Set HDG switch to each 30-degree increment position and observe indicator for corresponding indication.
- h.* Set ON-OFF switch to OFF to place in standby condition.

i. Disconnect cable W1 from 115Vac, 400Hz power for shutdown of test set.

2-7. Preparation For Movement

Prepare test set for movement as follows:

- a.* Position the clamp end of all cable connectors on the angle bracket of the control panel.
- b.* Push the excess length of all cables down through the cutout in the control panel.
- c.* Position cover hinge halves opposite case hinge halves and slide cover into position.
- d.* Close cover and secure the two latch-type fasteners.

CHAPTER 3

FUNCTIONING OF EQUIPMENT

3-1. Functioning of TS-2644 / ASN

a. Stepdown transformer T3 converts the 115Vac, 400Hz input power to 26Vac, 400 Hz. This 26Vac, 400Hz signal is used to excite the synchros in ID-998(*) / ASN. See figure 3-1 for functional block diagram and figure 3-2 for schematic diagram of the TS-2644/ ASN.

b. The input power frequency doubling circuit is comprised of transformer T1, diodes CR1 and CR2, capacitors C1, C2, and C3, and resistor R1. The circuit arrangement of T1, CR1, and CR2 converts the 400Hz input to a 800Hz squarewave. The 800Hz squarewave is changed to a sinusoidal wave by R1, C1, C2, and C3, then applied to transformer T2.

c. The 800Hz stepdown transformer reduces the 25Vac 800Hz output of the input power frequency doubler to 12.5Vac. The 12.5Vac power is applied

to the heading selector through the voltage adjust circuits.

d. Potentiometer R3 is used to set the desired voltage level for a selected heading of 30 degrees. The 0-degree voltage level is set by potentiometer R4.

e. Heading selector switch S3 applies 0- and 30-degree voltages to the voltage divider circuit through various combinations of six output leads.

f. The voltage divider converts combinations of six voltage inputs into a three-wire simulated magnetic heading output.

g. Mode selector switch S2 provides either an open or a short between 7P1-E and -P. An open circuit between 7P1-E and -P represents the DG mode. A closed circuit between 7P1-E and -P represents the MAG mode.

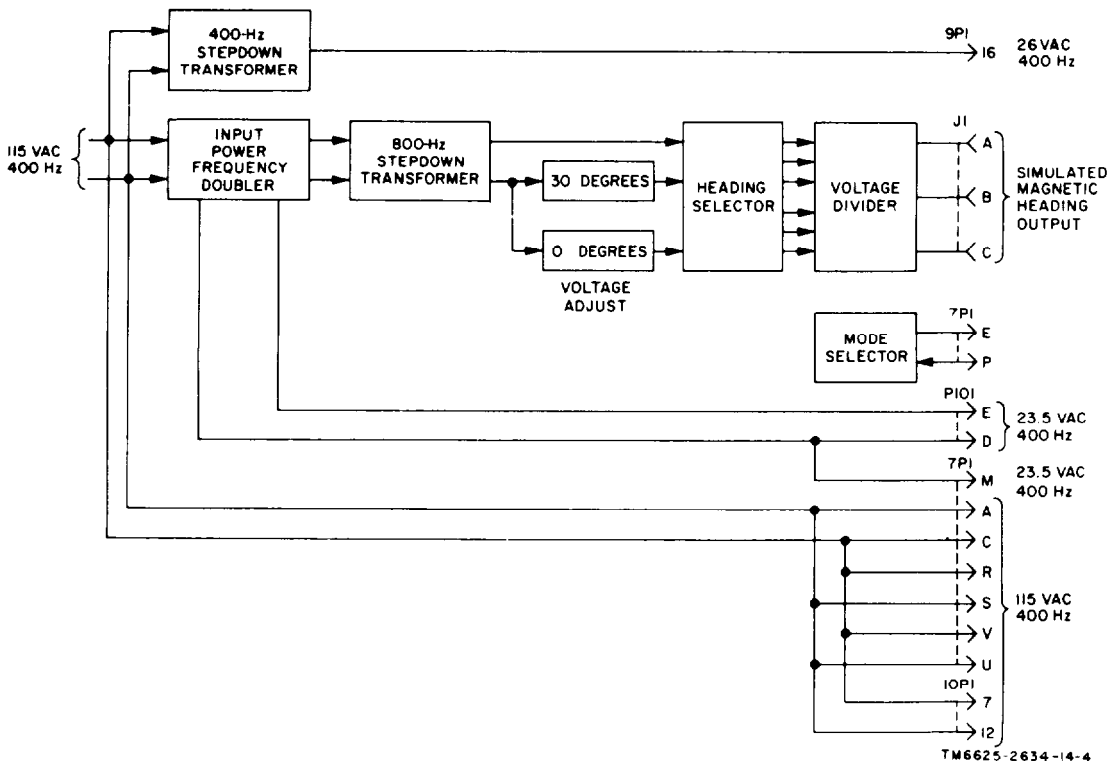

Figure 3-1. TS-2644 / ASN block diagram.

Figure 3-2. TS-2644 / AS/V schematic diagram,

(Located in back of manual.)

3-2. Functioning of TS-2645 / ASN

The functions of the TS-2645 / ASN are identical with the functions of the TS-2644 / ASN (para 3-

1). See figure 3-3 for block functional diagram and figure 3-4 for schematic diagram of the TS-2644/ ASN.

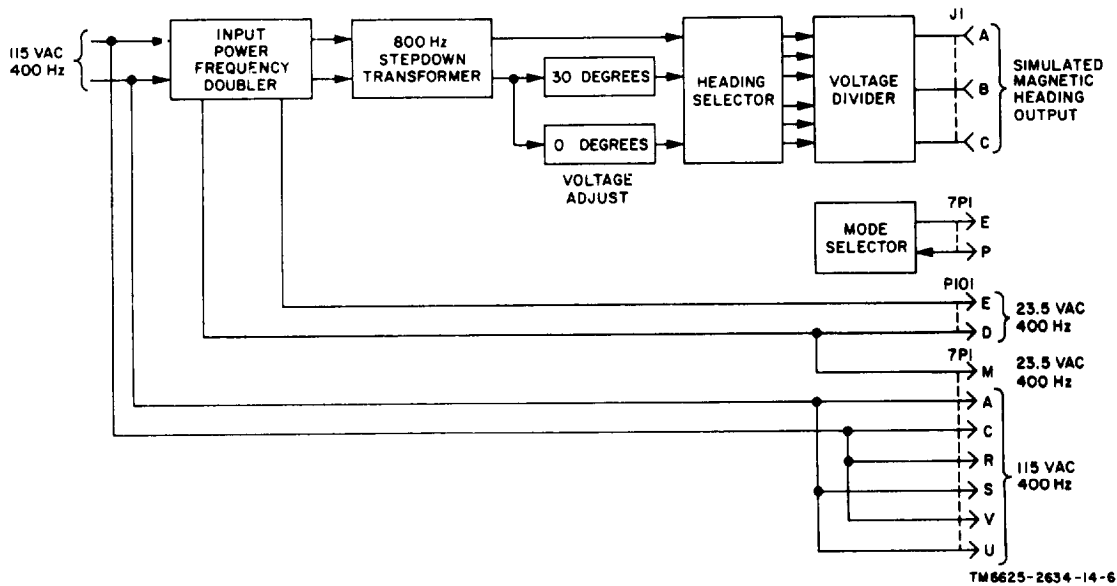

Figure 3-3. TS-2645 / ASN block diagram.

Figure 3-4. TS-2645 / ASN schematic diagram.
(Located in back of manual.)

CHAPTER 4

DIRECT SUPPORT AND GENERAL SUPPORT

MAINTENANCE INSTRUCTIONS

Section I. GENERAL

4-1. Direct Support Maintenance

Maintenance at the direct support level consists of replacement of the test set fuse which is located on the panel assembly.

4-2. Voltage and Resistance Measurements

a. No voltage measurements are required.

b. Resistance measurements are made using a multimeter with an accuracy of ± 5 percent.

4-3. Bench Testing

Bench testing of the test set consists of the two tests described below.

a. The insulation resistance test checks the test set and cable wiring for shorts or high voltage leaks through the insulation.

b. The continuity test checks point-to-point continuity between connectors and between front panel test points and connectors.

4-4. Tools and Test Equipment Required

Table 4-1 lists the tools and equipment required to test the test set.

Table 4-1. Tools and Test Equipment Required for General Support Maintenance

<i>Nomenclature</i>	<i>Use</i>
Insulation Breakdown Test Set AN / GSM-6 Multimeter AN / USM-223	Check resistance of wire insulation Check continuity of test set and cables.

Section II. TROUBLESHOOTING AND REPAIR

4-5. Troubleshooting Procedure

Troubleshooting the test set consists of performing the testing procedure in paragraph 4-7. If any abnormal test results are disclosed, return the test set to depot support for repair.

4-6. General Support Maintenance

General support maintenance of the test set consists of fuse and lamp replacements.

a. *Lamp Replacement.* Remove lampholder lens. Press on lamp and twist to the left to remove. Install new lamp and replace lampholder lens.

b. *Fuse Replacement.* Press fuseholder cap and twist to the left. Remove fuse. Install new 1-ampere fuse and replace fuseholder (cap).

Section III. GENERAL SUPPORT TESTING PROCEDURES

4-7. General

The test procedure is arranged so that tests that do not require power application to the test set are performed first. Test procedure steps shall be performed in the order listed. Set all test set and test equipment controls accurately.

4-8. Physical Tests and Inspection

a. *Test Equipment and Materials.* None.

b. *Test Connections and Conditions.* Remove test set cover from case. The test set power cable shall be disconnected from power source.

c. *Procedure.* Perform steps of table 4-2.

4-9. Insulation Resistance Test

(fig. 4-1)

a. *Test Equipment and Materials.* Insulation Breakdown Test Set AN / GSM-6.

b. *Test Connections and Conditions.* Minus (—) lead of AN / GSM-6 connected to test set chassis. Connect AN / GSM-6 to 115 Vac, 60Hz power source. Test set power cable shall be disconnected from power source.

c. *Procedure.* Perform steps of table 4-3.

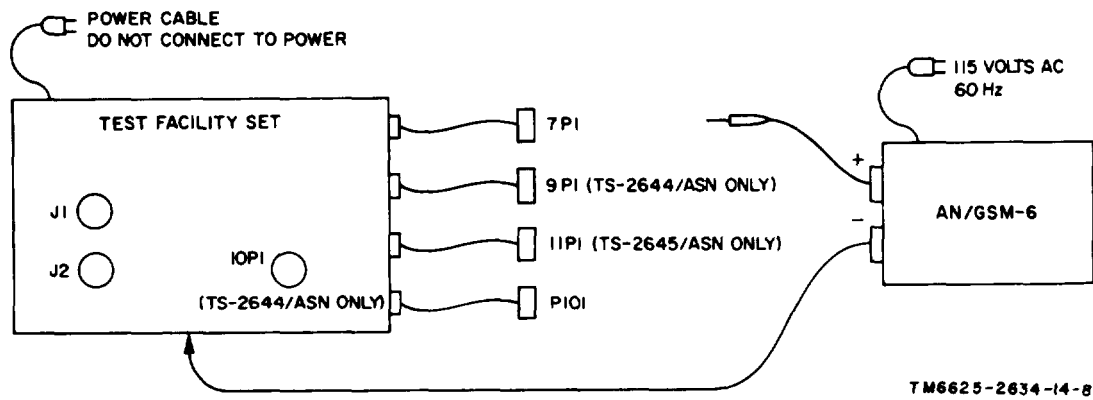

Figure 4-1. Insulation resistance test setup.

Table 4-2. Physical Test and Inspection

Step no.	Control settings		Test procedure	Performance standard
	Test equipment	Equipment under test		
1	N / A	Controls may be set in any position.	Inspect all controls and mechanical assemblies for loose or missing screws and nuts.	Screws and nuts must be tight, none missing.
2	N / A	Same as above.	Inspect all connectors for broken or bent pins and cracked connector case.	Connector pins must be straight and all pins present. Case must be free of cracks.
3	N / A	Same as above.	Inspect all cables for frayed or broken insulation.	Cable insulation must be free of breaks or excessively worn areas.
4	N / A	Same as above.	Inspect fuse for correct value.	Fuse must be rated at 1 amp.

Table 4-3. Insulation Resistance Test

Step no.	Control settings		Test procedure	Performance standard
	Test equipment	Equipment under test		
1 (TS-2644 / ASN)	AN / GSM-6: MULTI-PLIER to X1. DC ADJUST for 500 on VOLTS meter.	ON / OFF to OFF; all other controls may be set in any position.	Check insulation resistance from test set chassis to terminals of each connector except for terminal Z of 7P1 and green wire of power cable W1.	Insulation resistance from test set chassis to designated terminals shall be 10 megohms minimum at 500 Vdc.
2 (TS-2645 / ASN)	Same as above.	Same as above.	Check insulation resistance from test set chassis to terminals of each connector except for terminal Z of 7P1, j of 11P1, and green wire of power cable W1.	Insulation resistance from test set chassis to designated terminals shall be 10 megohms minimum at 500Vdc.

4-10. Continuity Test
(fig. 4-2)

a. Test Equipment and Materials.
Multimeter AN / USM-223.

b. Test Connections and Conditions. Test set power cable shall be disconnected from power source.

c. Procedure. Perform steps of table

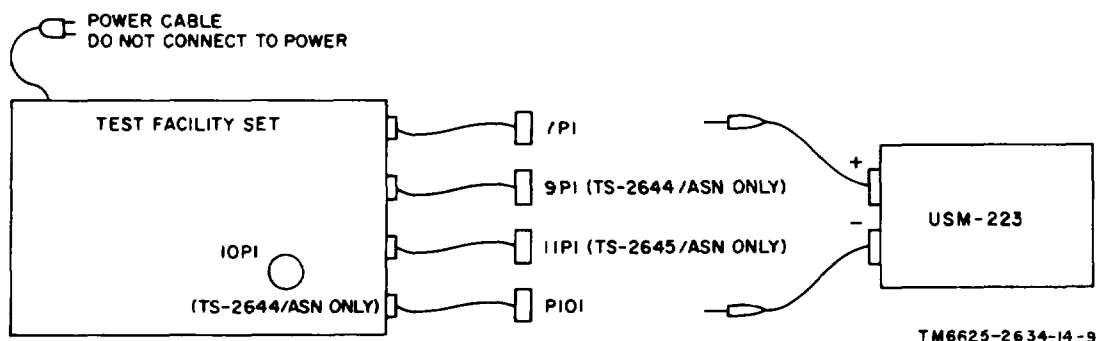

Figure 4-2. Continuity test setup.

Table 4-4. Continuity Test

Step no.	Control settings		Test procedure	Performance standard
	Test equipment	Equipment under test		
1 (TS-2644 / ASN)	AN / USM-223 controls to +DC and RX1	ON / OFF to ON. DG / MAG to MAG	Check resistance between terminals listed in table 4-5. Minus (—) lead of AN / USM-223 shall be connected to terminals in From column and (+) lead shall be connected to terminals in To column.	Resistance between terminals listed in table 4-5 shall be 1 ohm or less.
2 (TS-2645 / ASN)	Same as above.	Same as above.	Check resistance between terminals listed in table 4-6. Minus (—) lead of AN / USM-223 shall be connected to terminals in From column and plus (+) lead shall be connected to terminals in To column.	Resistance between terminals listed in table shall be 1 ohm or less.

Table 4-5. Continuity Test Points for TS-2644 / ASN

From	To	From	To	From	To
TP1	10P1-13	TP8	9P1-4	TP20	9P1-48
TP1	9P1-8	TP9	10P1-8	TP21	7P1-H
TP2	10P1-14	TP9	9P1-12	TP21	9P1-1
TP2	9P1-9	TP11	10P1-7	TP22	7P1-J
TP3	10P1-11	TP11	7P1-C	TP22	9P1-3
TP3	9P1-10	TP11	7P1-R	TP23	7P1-G
TP4	10P1-12	TP11	7P1-V	TP23	9P1-2
TP4	9P1-11	TP12	P101-B	TP24	7P1-E
TP4	9P1-55	TP12	9P1-42	TP24	7P1-P
TP4	7P1-A	TP13	P101-C	TP25	7P1-Z
TP4	P101-D	TP13	9P1-43	TP29	9P1-13
TP4	7P1-S	TP14	P101-A	TP30	9P1-14
TP4	7P1-U	TP14	9P1-44	TP31	9P1-15
TP4	9P1-17	TP16	7P1-M	TP32	7P1-W
TP5	10P1-6	TP17	7P1-D	TP33	7P1-X
TP5	9P1-5	TP17	9P1-45	TP34	7P1-Y
TP7	10P1-1	TP18	7P1-B	P101	7P1-F
TP7	9P1-6	TP18	9P1-46	P101	7P1-T
TP8	10P1-3	TP19	7P1-a	TP11	BLK *
TP8	9P1-7	TP19	9P1-51	TP4	WHT *
		TP20	7P1-b	TP25	GRN *

* Lead of power cable

Table 4-6. Continuity Test Points for TS-2645 / ASN

From	To	From	To	From	To
TP1	11P1-G	TP9	7P1-R	TP15	11P1-j
TP1	P101-C	TP9	7P1-C	TP15	7P1-Z
TP2	11P1-F	TP10	11P1-A	TP29	11P1-f
TP2	P101-B	TP10	11P1-a	TP30	11P1-g
TP3	11P1-H	TP10	7P1-S	TP31	11P1-h
TP3	P101-A	TP10	7P1-A	TP32	11P1-C
TP4	7P1-M	TP10	P101-D	TP32	7P1-H
TP5	7P1-a	TP11	11P1-J	TP33	11P1-D
TP5	11P1-d	TP11	7P1-W	TP33	7P1-J
TP6	7P1-b	TP12	11P1-K	TP34	11P1-E
TP6	11P1-e	TP12	7P1-X	TP34	7P1-G
TP7	7P1-V	TP13	11P1-L	P101F	7P1-D
TP7	7P1-T	TP13	7P1-Y	P101F	7P1-F
TP8	7P1-U	TP14	7P1-E	TP9	BLK *
TP8	7P1-B	TP14	7P1-P	TP10	WHT *
TP9	11P1-B	TP14	11P1-Z	TP15	GRN *

* Lead of power cable.

APPENDIX A

REFERENCES

DA Pam 310-4	Index of Technical Manuals, Technical Bulletins, Supply Manuals (types 7, 8, and 9), Supply Bulletins, and Lubrication Orders.
DA Pam 310-7	U.S. Index of Modification Work Orders.
TM 11-6625-273-12	Operation and Organizational Maintenance: Insulation Breakdown Test Sets AN / GSM-6 and AN/ GSM-6A.
TM 38-750	The Army Maintenance Management Systems (TAMMS).
TM 740-90-1	Administrative Storage of Equipment.
TM 750-244-2	Procedures for Destruction of Electronics Materiel to Prevent Enemy Use (Electronics Command).

APPENDIX B

MAINTENANCE ALLOCATION

Section I. INTRODUCTION

B-1. General

This appendix provides a summary of the maintenance operations covered in the equipment literature. It authorizes categories of maintenance for specific maintenance functions on reparable items and components and the tools and equipment required to perform each function. This appendix may be used as an aid in planning maintenance operations.

B-2. Maintenance Functions.

Maintenance functions will be limited to and defined as follows:

- a. Inspect.* To determine serviceability of an item by comparing its physical, mechanical, and electrical characteristics with established standards.
- b. Test.* To verify serviceability and to detect incipient electrical or mechanical failure by use of special equipment such as gages, meters, etc. This is accomplished with external test equipment and does not include operation of the equipment and operator type tests using internal meters or indicating devices.
- c. Service.* To clean, to preserve, to charge, and to add fuel, lubricants, cooling agents, and air. If it is desired that elements, such as painting and lubricating, be defined separately, they may be so listed.
- d. Adjust.* To rectify to the extent necessary to bring into proper operating range.
- e. Align.* To adjust two or more components or assemblies of an electrical or mechanical system so that their functions are properly synchronized. This does not include setting the frequency control knob of radio receivers or transmitters to the desired frequency.
- f. Calibrate.* To determine the corrections to be made in the readings of instruments or test equipment used in precise measurement. Consists of the comparison of two instruments, one of which is a certified standard of known accuracy, to detect and adjust any discrepancy in the accuracy of the instrument being compared with the certified standard.
- g. Install.* To set up for use in an operational environment such as an encampment, site, or vehicle.
- h. Replace.* To replace unserviceable items with serviceable like item.
- i. Repair.* To restore an item to serviceable condition through correction of a specific failure of unserviceable condition. This function includes, but is not limited to welding, grinding, riveting, straightening, and replacement of parts other than the trial and error replacement of running spare type items such as fuses, lamps, or electron tubes.
- j. Overhaul.* Normally, the highest degree of maintenance performed by the Army in order to minimize timework in process is consistent with quality and economy of operation. It consists of that maintenance necessary to restore an item to completely serviceable condition as prescribed by maintenance standards in technical publications for each item of equipment. Overhaul normally does not return an item to like new, zero mileage, or zero hour condition.
- k. Rebuild.* The highest degree of materiel maintenance. It consists of restoring equipment as nearly as possible to new condition in accordance with original manufacturing standards. Rebuild is performed only when required by operational considerations or other paramount factors and then only at the depot maintenance category. Rebuild reduces to zero the hours or miles the equipment, or component thereof, has been in use.
- l. Symbols.* The uppercase letter placed in the appropriate column indicates the lowest level at which that particular maintenance function is to be performed.

B-3. Explanation of Format

a. Column 1, Group Number. Column 1 lists group numbers, the purpose of which is to identify components, assemblies, subassemblies and modules with the next higher assembly.

b. Column 2, Functional Group. Column 2 lists the noun names of components, assemblies, subassemblies and modules on which maintenance is authorized.

c. Column 3, Maintenance Functions. Column 3 lists the maintenance category at which performance of the specific maintenance function is authorized. Authorization to perform a function at any category also includes authorization to perform that function at higher categories. The codes used

represent the, various maintenance categories as follows:

- Code Maintenance Category
- C Operator/Crew
- O. Organizational Maintenance
- F. Direct Support Maintenance
- H. General Support Maintenance
- D. Depot Maintenance

d. Column 4, Tools and Test Equipment. Column 4 specifies, by code, those tools and test equipment required to perform the designated function. The numbers appearing in this column refer to specific tools and test equipment which are identified in Table I.

e. Column 5, Remarks. Self-explanatory.

B-4. Explanation of Format of Table I, Tool and Test Equipment Requirements

The column in Table 1. Tool and Test Equipment Requirements are as follows:

a. Tools and Equipment. The numbers in this column coincide with the numbers used in the tools and equipment column of the applicable tool for the maintenance function.

b. Maintenance Category. The codes in this column indicate the maintenance category normally allocated the facility.

c. Nomenclature. This column lists tools, test, and maintenance equipment required to perform the maintenance functions.

d. Federal Stock Number. This column lists the Federal stock number of the specific tool or test equipment.

e. Tool Number. Not used.

SECTION II. MAINTENANCE ALLOCATION CHART															
GROUP NUMBER	COMPONENT ASSEMBLY NOMENCLATURE	MAINTENANCE FUNCTIONS										TOOLS AND EQUIPMENT	REMARKS		
		INSPECT	TEST	SERVICE	ADJUST	ALIGN	CALIBRATE	INSTALL	REPLACE	REPAIR	OVERHAUL			REBUILD	
	TEST FACILITY SET TS-2644/ASN & TS-2645/ASN	O	O	O	H									1 1,3 1,3 2,3 2,3,4 5 thru 10 5 thru 10 2 thru 10	Simulator voltage test Phase test

TABLE I. TOOL AND TEST EQUIPMENT REQUIREMENTS

TOOLS AND EQUIPMENT	MAINTENANCE CATEGORY	NOMENCLATURE	FEDERAL STOCK NUMBER	TOOL NUMBER
1	F,H,D	TOOL KIT, ELECTRONIC EQUIPMENT TK-100/G	5180-605-0079	
2	H,D	TOOL KIT, ELECTRONIC EQUIPMENT TK-105/G	5180-610-8177	
3	F,H,D	MULTIMETER AN/USM-223	6625-999-7465	
4	H,D	INSULATION BREAKDOWN T.S. AN/GSM-6	6625-542-1331	
5	D	OSCILLOSCOPE AN/USM-281	6625-740-0344	
6	D	PHASE SHIFTER KEARFOIT OR EQUIVALENT	6625-650-3387	
7	F,H,D	VTVM ME-26A/U	6625-542-6407	
8	D	LOAD RESISTORS (3) 100 ±0.1 OHMS		
9	D	DECADE CAPACITOR		
10	D	800 HZ READ-OUT SPERRY T321396 (DEPOT FAERICATED)		

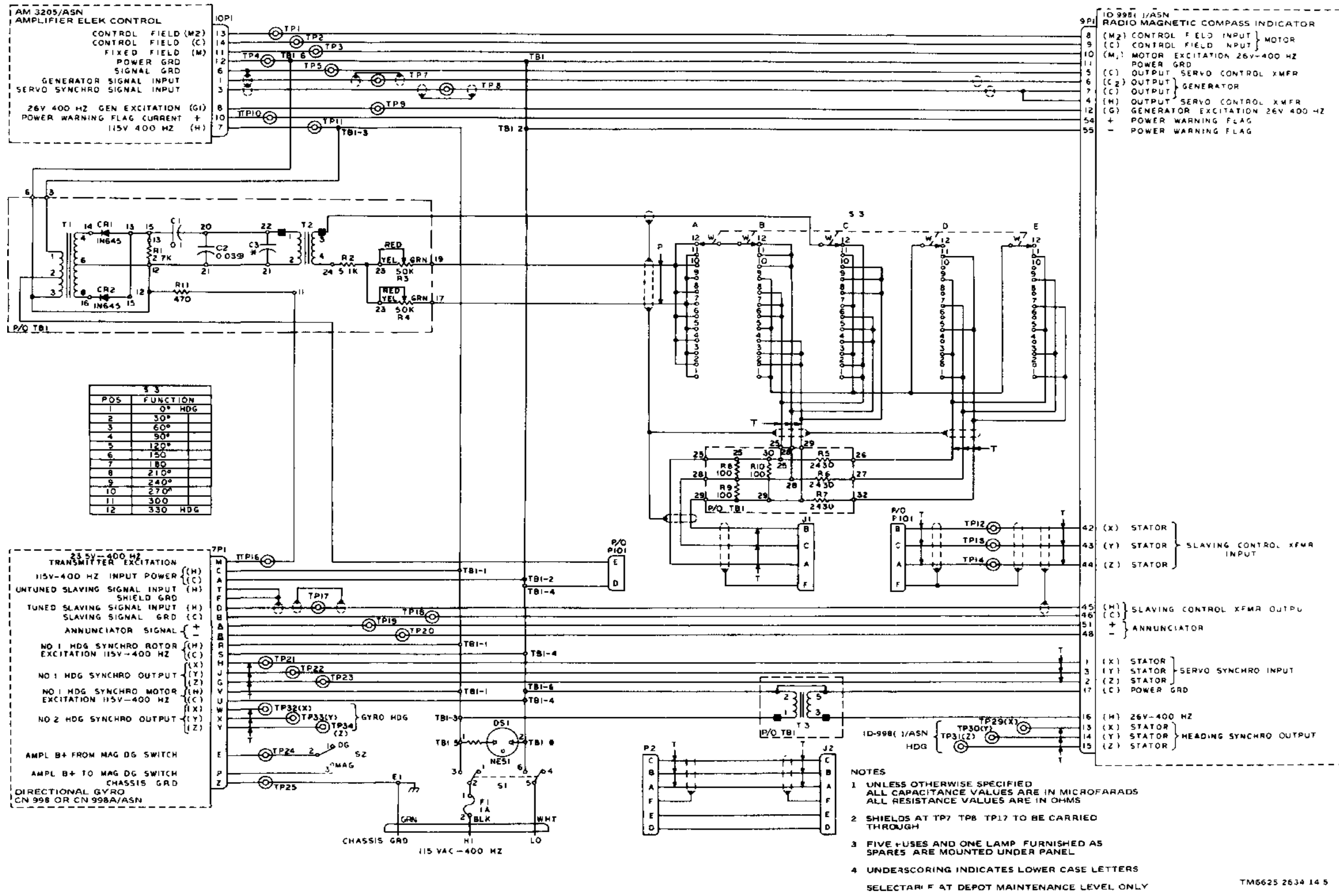

POS	FUNCTION
1	0° HDG
2	30°
3	60°
4	90°
5	120°
6	150°
7	180°
8	210°
9	240°
10	270°
11	300°
12	330° HDG

Figure 3-2. TS-2644/ASN schematic diagram

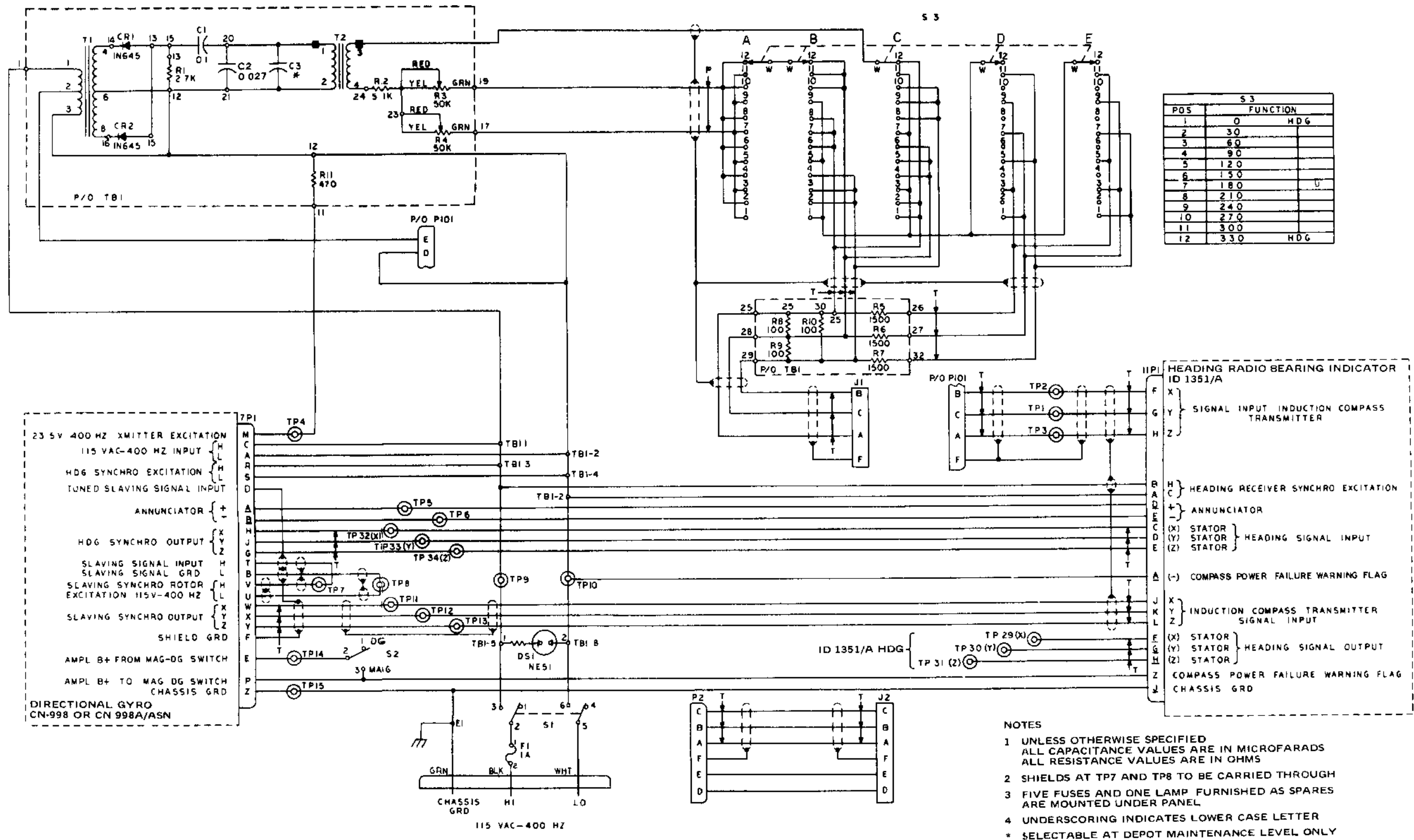

Figure 3-4. TS-2645/ASN schematic diagram

By Order of the Secretary of the Army:

CREIGHTON W. ABRAMS
General, United States Army
Chief of Staff

Official :

VERNE L. BOWERS
Major General, United States Army
The Adjutant General

Distribution:

To be distributed in accordance with DA Form 12-36 (qty rqr block no. 218).
Direct / General Support requirements for avionics literature, AN / ASN-43.

*U.S. GOVERNMENT PRINTING OFFICE : 1995 0 - 388-421 (00466)

RECOMMENDED CHANGES TO EQUIPMENT TECHNICAL PUBLICATIONS



THEN... JOT DOWN THE DOPE ABOUT IT ON THIS FORM, CAREFULLY TEAR IT OUT, FOLD IT AND DROP IT IN THE MAIL!

SOMETHING WRONG WITH THIS PUBLICATION?

FROM: (PRINT YOUR UNIT'S COMPLETE ADDRESS)

DATE SENT

PUBLICATION NUMBER

PUBLICATION DATE

PUBLICATION TITLE

BE EXACT... PIN-POINT WHERE IT IS

PAGE NO.

PARA-GRAPH

FIGURE NO.

TABLE NO.

IN THIS SPACE TELL WHAT IS WRONG AND WHAT SHOULD BE DONE ABOUT IT:

TEAR ALONG PERFORATED LINE

PRINTED NAME, GRADE OR TITLE, AND TELEPHONE NUMBER

SIGN HERE:

DA FORM 2028-2
1 JUL 79

PREVIOUS EDITIONS ARE OBSOLETE.

P.S.—IF YOUR OUTFIT WANTS TO KNOW ABOUT YOUR RECOMMENDATION MAKE A CARBON COPY OF THIS AND GIVE IT TO YOUR HEADQUARTERS.

